



PENNSYLVANIA LAWN PRODUCTS, INC.

Quality Mowers Since 1877

A Division of Virginia Metalcrafters, Inc.

1010 East Main Street
Waynesboro, Virginia 22980
Telephone 703:942-8205
Cable Address: VEEMET

Parts List

Panzer Tractor Models T75 and T758ES

When ordering Panzer parts always give the model number of the Tractor, the figure and part number, and the name of the part.

In all cases where standard hardware, belts or similar parts can be used their sizes are indicated. The entire Panzer rear axle assembly is a rebuilt Plymouth rear end. Where regular automobile repair parts can be used this is indicated by (*). Rears from a wide range of years prior to 1957 are used but only in case of oil seal size and number of axle spline

teeth is there significant difference. No axle outer seals are reinstalled in Panzer Tractor rear ends.

Engines are covered by separate Engine Mfg. warranty and parts lists. Parts for them are not handled by Panzer, but must be obtained from Engine Dealers.

Panzer reserves the right to change parts, design, materials and specifications without notice.

Fig. No.	Part No.	Name & Description	Quan.	
			T75	T758
1	T75-448	Frame Weldment	1	1
2	(*)T102-79	Differential Gear (Complete Assy.)	1	1
3	(*)T102-115	Pinion Seal	1	1
4	(*)T102-78	Flange	1	1
5	(*)T70-347	Spacer (Located in Diff.)	1	1
6	(*)T70-348	Slotted Nut (3/4-16 Hex.)	1	1
7	2802	Cotter Pin (1/8 x 1 1/2)	1	1
8	(*)T70-362	Diff. Bolt (Special 3/8-24 x 1 1/2)	11	11
9	2602	Lockwasher (3/8 Split)	25	29
10	2762	Washer (Annealed Copper)	4	4
11	2543	Lock Nut (Elastic 3/8-24)	4	4
12	2552	Hex. Nut (3/8-24 Case Hardened)	11	11
13	(*)T70-369	Gasket (Located in Diff.)	1	1
14	T50-173	Sprocket (#40-68 Teeth - 1" Bore)	1	1
15	2007	Hex. Cap Screw (3/8 - 24 x 1)	10	9
16	(*)T102-75 lg.	Inner Seal (Located in Diff. Housing)		
	(*)T102-75 sm.	Indicate Whether 2 11/16 or 2 7/16 OD	2	2
17	T50-190-16 sp.	Axle		
	T50-190-10 sp.	(Indicate Whether 16 or 10 Spline Teeth)	2	2
18	(*)T70-370	Bearing Race	2	2
19	(*)T70-371	Brake Plate Bolt (Special 3/8-24 x 1 1/8)	8	8
20	(*)T70-372	Shim (1/32 Velumoid)	8	8
21	T70-373	Seal Shim (1/32 Velumoid)	2	2
22	T75-452R	Brake Plate Weldment, Right	1	1
	T75-452L	Brake Plate Weldment, Left	1	1
23	T65-355	Brake Adjustment Stud	2	2
24	T65-353	Brake Adjustment Sleeve	2	2
25	T65-354	Clevis	2	2
26	(*)T102-70	Brake Shoe	2	2
27	(*)T65-356	Anchor Nut	2	2
28	(*)T65-356	Eccentric Bolt	2	2
29	(*)T65-356	Felt Washer	2	2
30	(*)T65-356	Felt Washer Cap	2	2
31	(*)T65-356	Washer (5/8 ID x 1" OD x .078)	2	2
32	(*)T65-350	Brake Spring	2	2
33	2023	Brake Plate Nut (3/8 - 24 Used)	8	8
34	(*)T70-375	Axle Key (5/16 x 5/16 x 2 1/4)	2	2
35	(*)T102-71	Brake Drum (Lug Bolt Holes Tapped Out to 9/16 - 18)	2	2
36	2724	Washer (3/4 ID x 1 1/2 OD x 1/8)	2	2
37	2507	Hex. Nut (3/4 - 16)	2	2
38	3189	Pipe Plug (1/4 IPS Steel)	1	1
39	T65-357	Brake Adjustment Cover	2	2
40	T70-359	Lift Handle Weldment	1	1
41	T70-291A	Lift Trigger	1	1
42	T70-361	Lift Trigger Pivot	1	1
43	2402	Hex. Cap Screw (1/4 - 28 x 1)	3	3
44	2513	Lock Nut (1/4 - 28)	17	17
45	T70-377	Lock Rod	1	1
46	2813	Cotter Pin (3/32 x 1/2)	1	1
47	2713	Washer (.627/.630" ID x 1" OD x .078)	1	1
48	2801	Cotter Pin (1/8 x 1)	1	1
49	T60-206	Hand Grip	1	1
50	T70-378	Spring (Compression)	1	1
51	2390	Hex. Cap Screw (3/8 - 24 x 2 Special)	1	1
52	T70-380	Washer (13/32 ID x 1 3/4 OD x 10 ga.)	1	1
53	T70-363	Lift Gear	1	1

Fig. No.	Part No.	Name & Description	Quan.	
			T75	T758
54	2705	Washer (3/8 Flat)	3	7
55	2504	Hex. Nut (3/8 24)	7	11
56	T70-418	Front Fender Bracket	2	2
57	T70-419	Rear Fender Bracket	2	2
58	T70-447	Battery Cable (15" #15-55-4)	-	2
59	2450	Hex. Cap Screw (3/8 - 24 x 1 1/4)	1	2
60	T70-368	Parking Brake	1	1
61	T70-417	Spring Washer (#ARC-664)	1	1
62	2527	Hex. Jam Nut (3/8 - 24)	1	1
63	2011	Hex. Cap Screw (1/2 - 20 x 2 1/2)	1	1
64	2512	Hex. Jam Nut (1/2 - 20)	1	1
65	T60-131A	Drive Casting	1	1
66	T50-127	Flange Bushing (3/4 ID x 1" OD x 3/4)	2	2
67	T50-117	Grease Fitting (1/8 NPT)	7	7
68	T50-162	Shaft & Sprocket Weldment	1	1
69	2720	Washer (.752/.757" ID x 1 1/8 x 1/8)	1	1
70	T50-163	Drive Rest Casting	1	1
71	2354	Set Screw (3/8 - 16 x 3/8 Soc. Hd.)	3	3
72	T70-384	Drive Pulley	1	1
73	2357	Set Screw (3/8 - 16 x 1 Sq. Hd.)	2	2
74	2735	Washer (49/64 ID x 1 1/4 OD x 1/16)	2	2
75	T60-249	Key (3/16 x 3/16 x 2)	1	1
76	T65-323	Drive Chain (#40 ASA - w/conn. link 38")	1	1
77	T65-323A	Connecting Link (#40 ASA)	1	1
78	T75-455	Foot Rest Rod	1	1
79	T50-147	Collar (3/4 Bore)	7	7
80	2350	Set Screw (1/4 - 20 x 1/4 Soc. Hd.)	9	9
81	T70-315A	Shift Lever	1	1
82	T70-435	Angle Grease Fitting (1/8 NPT 67 1/2°)	2	2
83	T65-329	Shift Grip	1	1
84	2851	Roll Pin (3/16 D x 1 1/8)	1	1
85	T65-331	Shift Lever Rod	1	1
86	T65-334	Grip Ring (#5555-25)	1	1
87	T65-335	Shift Rod Spring (5/16 ID x 3/8 OD x 1 3/8 comp.)	2	2
88	T60-260	Shift Lever Trip	1	1
89	2403	Hex. Cap Screw (1/4 - 28 x 1 3/4)	1	1
90	2702	Washer (1/4 Flat)	7	10
91	T65-333	Trip Spring	1	1
92	T65-326	Chain Guard Cover	1	1
93	2439	Sheet Metal Screw (#14 x 5/8 Type "A" Hex.)	2	2
94	T75-459R	Brake Pedal, Right	1	1
	T75-459L	Brake Pedal, Left	1	1
95	3287	Adhesive Abrasive	2	2
96	T65-338	Battery Plate	-	1
97	2386	Carriage Bolt (1/4 - 20 x 6)	-	1
98	3288	Seat Spring (Tuthill #3234)	1	1
99	T70-434	Tool Box	1	1
100	2423	Carriage Bolt (1/2 - 13 x 1 1/4)	3	1
101	2442	Carriage Bolt (1/2 - 13 x 1 1/2)	-	2
102	2607	Lockwasher (1/2 Ext. #1124 Sp.)	5	5
103	2505	Hex. Nut (1/2 - 13)	5	5
104	T60-225	Shock Plate	1	-
105	T60-226	Shock Mounts	3	3
106	T60-227	Rivet (5/32 D x 1/2 Rd. Hd.)	6	6
107	T70B-407A	B & S Engine (6 Hp.)	1	-
108	2406	Hex. Cap Screw (5/16 - 18 x 1 3/4)	4	-

Fig. No.	Part No.	Name & Description	Quan.	
			T75	T758
109	2601	Lockwasher (5/16 Split)	4	1
110	2502	Hex. Nut (5/16 - 18)	4	4
111	3252	Key Starter Switch (C-H #95516-A)	1	1
112	3313	Magneto Wire With Terminals	1	-
113	T70-382	Drive Pucker	1	-
114	2397	Hex. Cap Screw (5/16 - 18 x 1)	4	2
115	2703	Washer (5/16 Flat)	4	-
116	2610	Lockwasher (5/16 Ext. #1118 Sp.)	2	-
117	3289	Throttle Control (Throttle & Choke)	1	1
118	3291	Throttle Clip (#3)	1	1
119	2700	Washer (Stanley #991-7)	1	3
120	2426	Mach. Screw (10-32 x 3/8 Rd. Hd.)	1	-
121	T707-425	Shock Plate	-	1
122	T758-461	Kohler Engine (8 Hp.)	-	1
123	T707-463	Raising Bar	-	2
124	2390-A	Hex. Cap Screw (3/8 - 24 x 2)	-	4
125	T65-342	Ground Strap (#8EG2)	-	1
126	T758-511	Drive Pucker	-	1
127	2408	Hex. Cap Screw (3/8 - 16 x 3/4)	-	2
128	T75-480	Choke Mtg. Tab	-	1
129	2424	Mach. Screw (10 - 24 x 1/2 Rd. Hd.)	-	5
130	2500	Hex. Nut (10 - 24)	-	5
131	2604	Lockwasher (3/16 Ext. #1110 Sp.)	-	5
132	T758-506	Voltage Regulator Plate	-	1
133	T758-507	Voltage Regulator Support	-	1
134	T758-508	Belt Guard Bracket	-	1
135	2464	Hex. Cap Screw (5/16 - 18 x 1 1/4)	2	3
136	T758-505A	Belt Guard	-	1
137	40140	Washer (21/64 ID x 1" OD x 1/16)	-	4
138	2600	Lockwasher (1/4 Split)	5	7
139	3253	Solenoid (C-H #24046)	-	1
140	3313-A	Amp. Wire (w/Terminals)	-	1
141	3313-B	Solenoid Wire (w/Terminals)	-	1
142	3313-C	Magneto Wire (w/Terminals)	-	1
143	3313-D	Voltage Wire (w/Terminals)	-	1
144	3290	Battery Cable (39")	-	1
145	T70-439	Cup Washer (3/32 Cup)	3	-
146	T70-443	Cup Washer (5/32 Cup)	3	6
147	2389	Hex. Cap Screw (1/4 - 28 x 2)	2	2
148	2404	Hex. Cap Screw (1/4 - 28 x 3 1/2)	1	1
149	2401	Hex. Cap Screw (1/4 - 28 x 3/4)	8	10
150	2524	Hex. Nut (1/4 - 28)	-	2
151	T70-381	Engine Pulley	1	1
152	T102-7	Reverse Disc	1	1
153	T102-8	Reverse Disc Plate	1	1
154	2461	Hex. Cap Screw (1/4 - 20 x 1 1/2)	5	5
155	T60-250	Key (1/4 x 1/4 x 2)	1	1
156	T50-167	Drive Belt (5L340)	1	1
157	T75-467	Grill	1	1
158	T75-468	Hood	1	1
159	T75-470	Gas Tank Strap	2	2
160	2741	Washer (Stanley 991-2)	10	10
161	3292	Gas Tank (4 Qts.)	1	1
162	T70-420	Shut Off Valve	1	1
163	T70-436	Tank Spacer (Rubber)	1	1
164	2461-A	Hex. Cap Screw (1/4 - 28 x 1 1/2)	1	1
165	T75-445	Pillow Block	1	1
166	T75-477	Dash Panel	1	1
167	3298	Seal (Conduit)	1	-
168	T75-478	Steering Shaft	1	1
169	T75-501	Pinion Gear	1	1
170	5199	Key (1/4 x 1/4 x 1 1/2)	1	1
171	2353	Set Screw (5/16 - 18 x 3/8 Soc. Hd.)	4	4
172	6007	Washer (17/64 ID x 3/4 OD x 1/16)	1	1
173	T70-444	Steel Ball (5/16)	1	1
174	3295	Amperes Meters (#4015-Range 20-0-20)	-	1
175	2501	Hex. Nut (1/4 - 20)	1	1
176	T70-353A	Pittman Shaft	1	1
177	T75-479	Pittman Housing	1	1
178	T75-502	Steering Quad. Gear	1	1
179	2877	Groov-Pin (1/4 D x 1 3/4)	2	2
180	T75-486	Steering Link	2	2
181	T70-405	Grommet (#828 37006)	4	4
182	T70-403	Sleeve	4	4
183	2541	Hex. Jam Nut (5/16 - 18)	6	6
184	2385	Hex. Cap Screw (1/4 - 20 x 6)	-	1
185	T65-339	Battery Clamp	-	1
186	2540	Wing Nut (1/4 - 20)	-	2
187	T65-343B	Battery Cable Grommet (#2285)	-	2
188	T102-76	Seat	1	1
189	T70-392	Spring Bracket	1	1
190	2475	Carriage Bolt (3/8 - 16 x 1 1/4)	1	1
191	2606	Lockwasher (3/8 Ext. #1120 Sp.)	9	11
192	2503	Hex. Nut (3/8 - 16)	1	1
193	2467	Hex. Cap Screw (1/2 - 13 x 3)	2	2
194	T75-469	Front Axle	1	1
195	T75-492R	Front Wheel Axle, Right	1	1
	T75-492L	Front Wheel Axle, Left	1	1
196	2734	Washer (49/64 ID x 1 1/4 OD x 1/8)	2	2
197	T50-126	Shaft Cap	2	2
198	2754	Washer (1 1/64 ID x 2" OD x .075)	2	2
199	T50-131	Retaining Ring (#5100-100)	1	1
200		Gas Hose w/Clamps (Comes w/Engines)	1	1
201	T60-248	Key (1/4 x 1/4 x 1)	1	1
202	3286	Steering Wheel	1	1
203	T70-411	Rear Lift	1	1

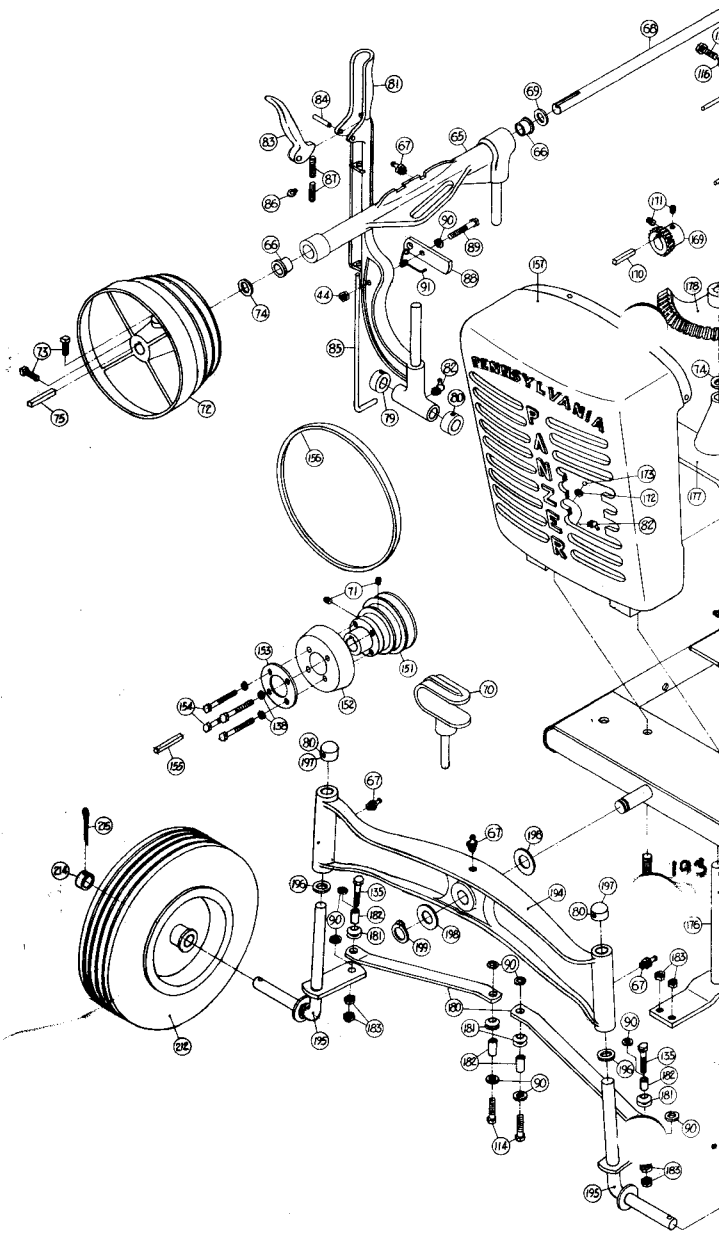
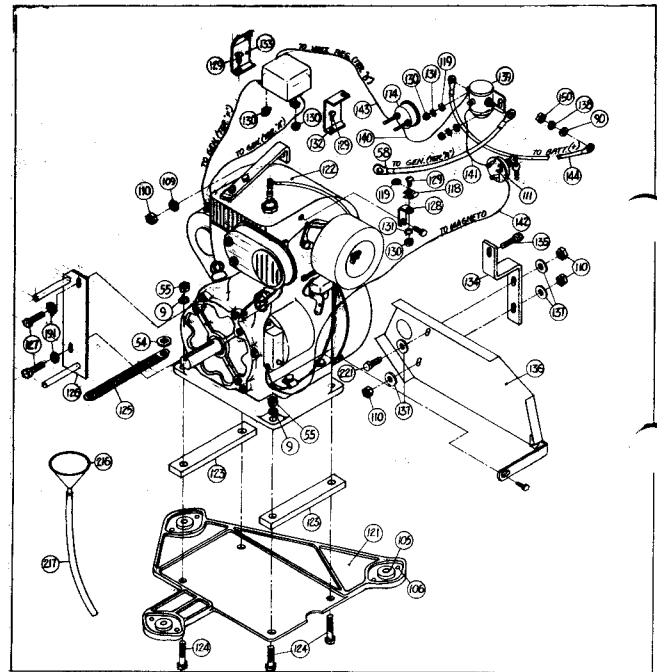

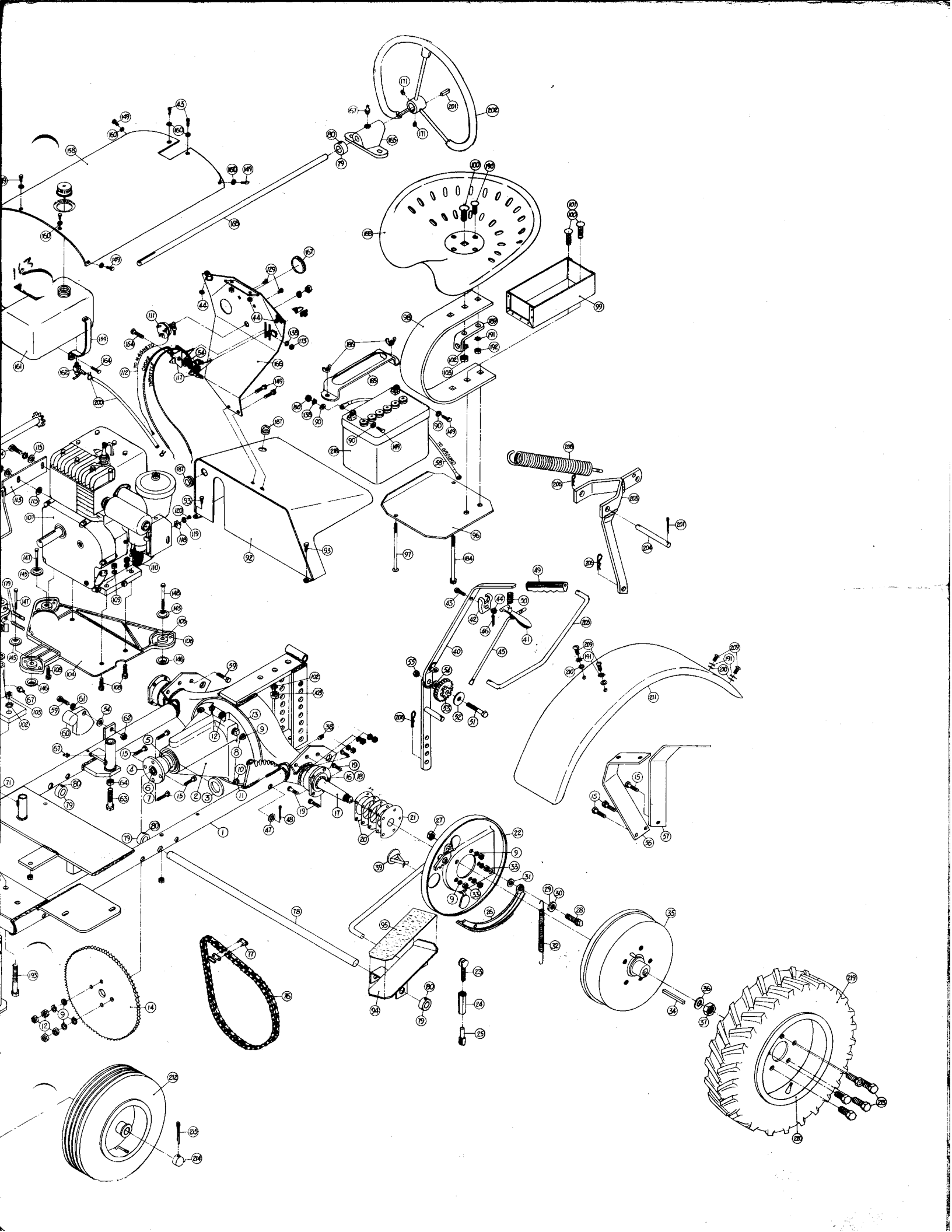

Fig. No.	Part No.	Name & Description	Quan.		Fig. No.	Part No.	Name & Description	Quan.	
			T75	T758				T75	T758
204	T70-412	Rear Lift Pin	1	1	213	T102-52	Lug Bolt (9/16 - 18 x 1 1/4 Hex.)	10	10
205	T70-413	Lift Link	1	1	214	T50-126D	Shaft Cap	2	2
206	2905	Clip Pin(#3)	3	3	215	2805	Cotter Pin (3/16 D x 1 1/2)	2	2
207	2801	Cotter Pin (1/8 D x 1)	1	1	216	3254	Plastic Funnel (For Putting Oil in Engine)	-	1
208	T70-415	Rear Lift Spring (#0S 51260)	1	1	217	3255	Polyethylene Tube (For Putting Oil in Eng.)	-	1
209	2393	Mach. Screw (3/8 - 16 x 1/2 Truss Hd.)	8	8	218	T65-340	Battery (12 Volt Type Lu-7)	-	1
210	T70-441	Fibre Washer (13/32 ID x 11/16 OD x 1/32 White)	8	8	219	T50-119	Lug Tire & Tube (6-12) { Specify	2	2
211	T70-416	Fender	2	2	220	T50-119	Lawn Tire & Tube (6-12) { Tread Type	2	2
212	3296	Front Wheel (5.30-4.50-6 2 Ply)	2	2	221	T50-118	Wheel (Dico 12")	2	2
						2405	Hex. Cap Screw (5/16 - 18 x 3/4)	-	1

Remember when ordering, give figure number, part number and name of part wanted as well as tractor model number.

Panzer tractors are covered by the following warranty.

PANZER TRACTOR WARRANTY

For one year from purchase date, Pennsylvania Lawn Products, Inc. will replace for the original purchaser, any part or parts found upon examination at the Panzer factory to be defective under normal use and service, on account of defects in material or workmanship, PROVIDED A WARRANTY REGISTRATION CARD HAS BEEN PROPERLY FILLED OUT AND IS ON FILE AT THE PENNSYLVANIA LAWN PRODUCTS, INC. FACTORY. All transportation charges on parts submitted for replacement under warranty, are to be borne by purchaser. This warranty covers Panzer tractors and Panzer attachments manufactured by Pennsylvania Lawn Products, Inc. It does not include tractor engines, tractor tires, batteries and attachments which are manufactured by companies other than Pennsylvania Lawn Products, Inc. The items which

are excluded from Panzer's warranty are subject to the warranty of the original manufacturer. The Panzer warranty is ineffective if equipment has been subject to misuse, negligence, or accident, or if it has been repaired or altered in any respect which, in our judgment, affects its condition or operation. There is no other warranty expressed or implied. Pennsylvania Lawn Products, Inc. shall in no event be liable for consequential damage. Further Pennsylvania Lawn Products, Inc. neither assumes nor authorizes any other person to assume for it any other liabilities in connection with the sale of tractors or attachments. This warranty does not apply to Panzer equipment used commercially.

All These Attachments Will Fit Your Panzer

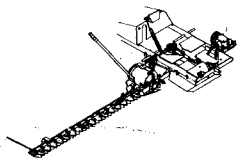

Sickle Bar 9AC5

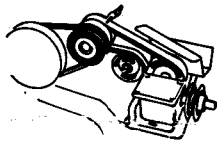

Power Take-Off Kit 55PT

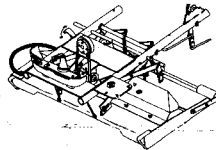

Mower 11AC11

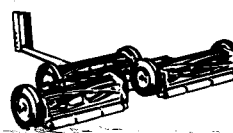

Reel Mower Unit W21-T

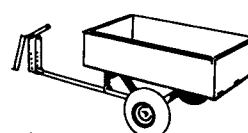

Dump Cart 14AC1

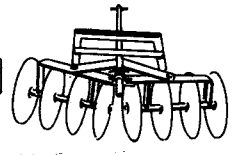

Disc Harrow 6AC2

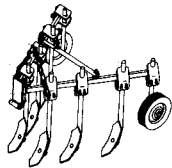

Cultivator 3AC4BH2

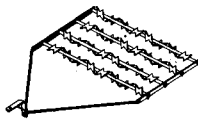

Spike Tooth Harrow TH1

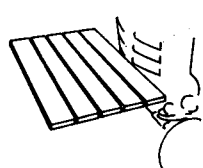

Front Utility Rack 4AC5

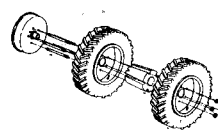

Wheel Weights TA22

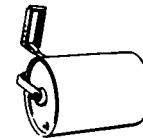

Roller 525

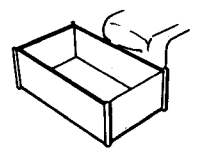

Front Utility Box 4AC4

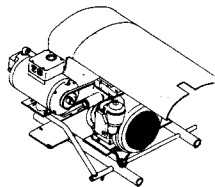

Generator 16AC1

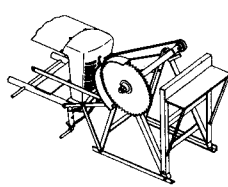

Power Saw 15AC1



Umbrella TA60

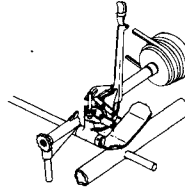

Foot Pedal TA26

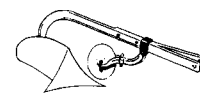

Plow 1AC6 Coulter C02C

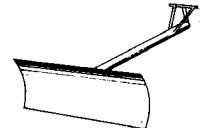

Snowplow Blade 10AC4

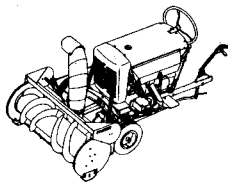

Snow Thrower 17AC2



Seat Cushion TA40

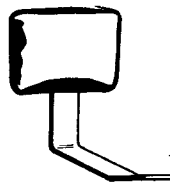

Seat Back TA65

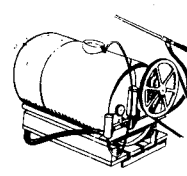

Power Sprayer 12AC1

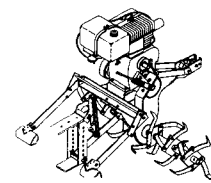

Power Tiller 13AC2

Pennsylvania Lawn Products, Inc.

DIVISION OF VIRGINIA METALCRAFTERS, INC.

Waynesboro, Virginia 22980

